

Model 2702

50 Hz 60 Hz

Submersible Grinder Pump

Features:

- Hardened 440 stainless steel (56-60 Rockwell) shredding ring and cutter
- Cast iron ASTM A48 Class 30
- Semi-open impeller design prevent clogging
- Ductile iron impeller for superior quality and long life
- Double carbon / ceramic mechanical seal
- Thermal overload is mounted directly on the windings in the single phase models for maximum temperature sensing
- Oil-filled motor for better cooling and lubrication
- The cord seal is epoxy-potted for superior moisture resistance and anti-wicking
- 1-1/4" NPT discharge
- Standard 10 m (33') 50 Hz / 9 m (30') 60 Hz cord
- Horizontal discharge available
- Simplex and duplex systems available
- Packaged systems available

Consult factory for special applications:

- Control panel available: simplex – P/N 10-3475, duplex – P/N 10-3476
- Rail systems available: P/N 2039-0006 (2" BSPT), 2039-0004 (2" NPT)
- Minimum recommended basin size (small load applications): simplex – 18" x 30" (460 x 760 mm), duplex – 30" x 36" (760 x 910 mm)
- High water alarms available

Applications:

- Low pressure sewer systems
- High head sewage systems
- Domestic, commercial, wastewater and sewage

100% factory tested



Trusted. Tested. Tough.®



Grinder Blade

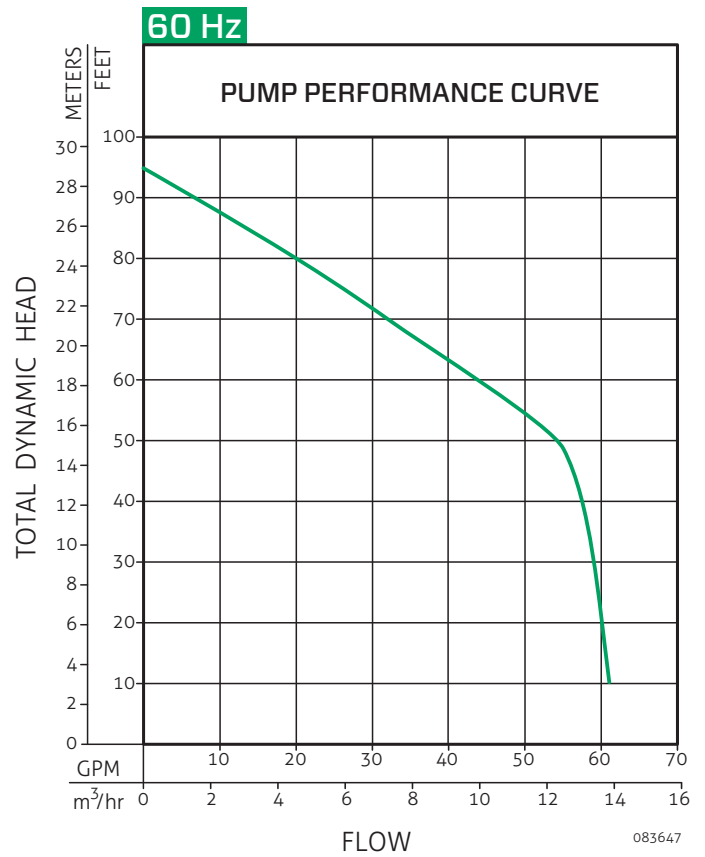
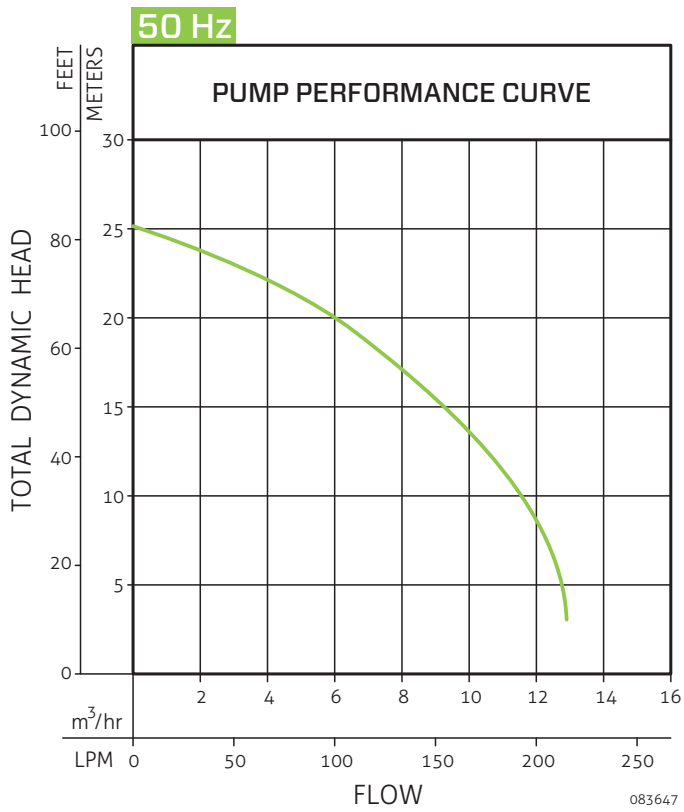

50 Hz

Model	Mode	Volts (V)	Ph Ø	Amps (A)	Motor		Weight	
					kW (p1)	HP	kg	lbs
V2702	Non	220-240	1	10.0	2.2	1	33.5	74
WU2702	Auto-Tethered	220-240	1	10.0	2.2	1	34.0	75
AK2702	Non	380	3	4.0	2.2	1	33.5	74

60 Hz

Model	Mode	Volts (V)	Ph Ø	Amps (A)	Motor		Weight	
					HP	kW (p1)	kg	lbs
BL2702	Non	220	1	14.0	1	3.0	34.0	75



*Intended for indoor use only.

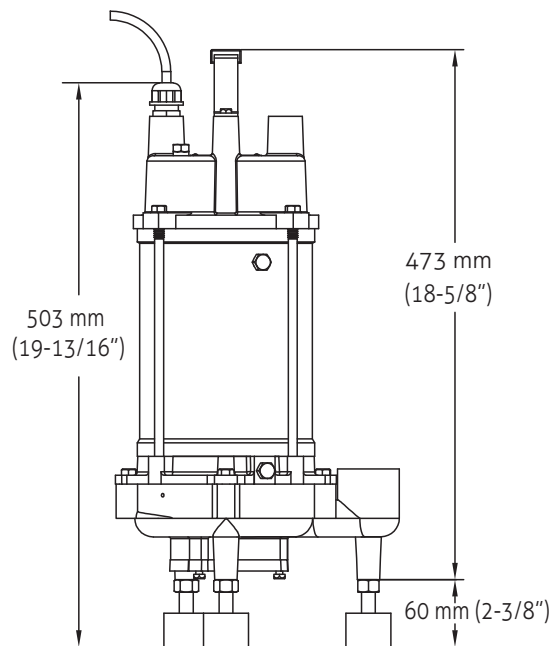
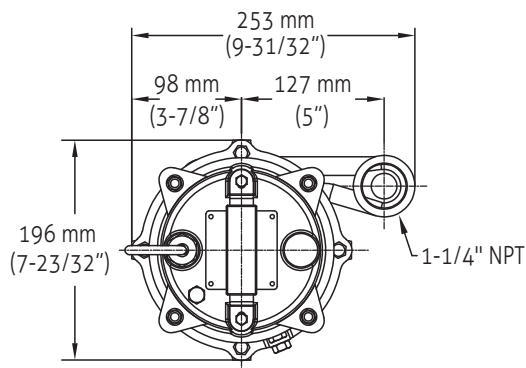

EA0122

Product information presented here reflects conditions at time of publication. Consult factory regarding discrepancies or inconsistencies.

© Copyright 2020 Zoeller® Co. All rights reserved.
www.zoellerpumps.com

