

Qwik Jon[®] CHOICE

50 Hz 60 Hz

Making bathroom installations easy!

Features and Benefits:

- A quiet, preassembled pump and macerator system requiring minimal space for installation!
- Install a complete bathroom without breaking concrete!
- Easily connects to a tub, shower, sink, or other fixtures with 2" NPT or 1-1/2" (DN25) slip side inlets
- No gravity drain required
- Install as a freestanding unit
- Automatic reset thermal overload protects the pump
- Carbon/Ceramic mechanical shaft seal for long life
- Upper and lower ball bearings for efficient and quiet operation
- Non-clogging vortex impeller for reliable operation
- Recessed side handles for carrying
- Convenient snap-fit covers for easy access to macerator and electrical junction box
- Discharge elbow with built-in check valve
- Standard 6' (1.8 m) cord
- For recessed or behind-the-wall installations, use Extension Kit p/n 10-3050



100% factory tested

ZOELLER[®]
PUMP COMPANY

Trusted. Tested. Tough.[®]

FM3289_Ec
0521
Supersedes
NEW

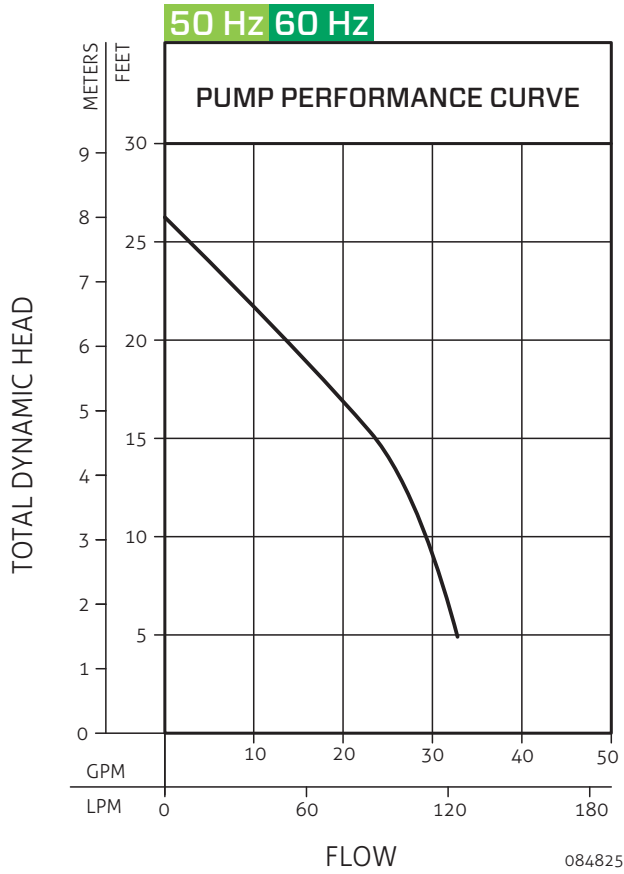

50 Hz

Model	Mode	Volts (V)	Ph Ø	Amps (A)	Motor		Weight	
					kW (p1)	HP	kg	lbs
200	Vertical Switch	220	1	2.5	0.46	1/3	11	24.3

60 Hz

Model	Mode	Volts (V)	Ph Ø	Amps (A)	Motor		Weight	
					HP	kW (p1)	kg	lbs
200	Vertical Switch	115	1	6.0	1/3	0.66	11	24.3

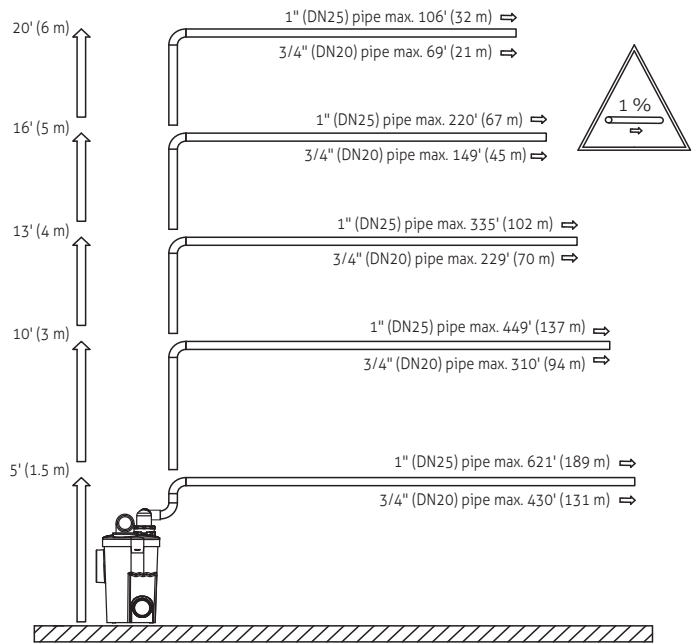
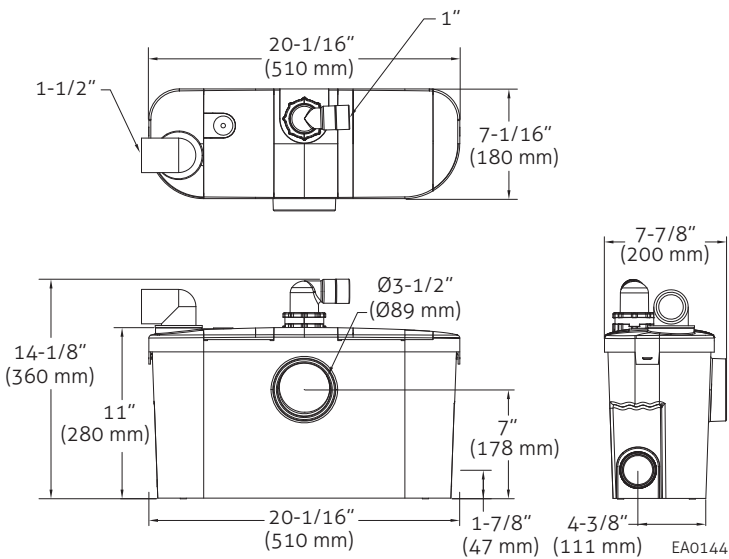

Product information presented here reflects conditions at time of publication. Consult factory regarding discrepancies or inconsistencies.

© Copyright 2021 Zoeller® Co. All rights reserved.
www.zoellerpumps.com

