

Qwik Jon®

PREMIER

50 Hz 60 Hz

Making bathroom installations easy!

Features and Benefits:

- A quiet, preassembled grinder pump system requiring minimal space for installation!
- Install a complete bathroom without breaking concrete!
- Easily connects to a tub, shower, sink, or other fixtures with 2" NPT or 1-1/2" (DN25) slip side inlets
- No gravity drain required
- Install as a freestanding unit
- Automatic reset thermal overload protects the pump
- Carbon/Ceramic mechanical shaft seal for long life
- Upper and lower ball bearings for efficient and quiet operation
- Non-clogging vortex impeller for reliable operation
- Recessed side handles for carrying
- Withstands total immersion (IP68)
- 1" Discharge elbow with built-in check valve
- Standard 6' (1.8 m) cord with right angle plug
- Tri-Slice® Cutter Technology - three independent cutting channels, 50 Hz - provide over 200,000 cuts per minute, 60 Hz - provide over 250,000 cuts per minute
- Premium investment-cast 440C stainless steel cutter and cutter plate
- For recessed or behind-the-wall installations, use Extension Kit p/n 10-3050
- Optional high water Qwik Alarm for Qwik Jon® Premier p/n 10-5090



10-5090



10-3050

100% factory tested

ZOELLER 
PUMP COMPANY

Trusted. Tested. Tough.®

FM3290_Ec
0722
Supersedes
0521

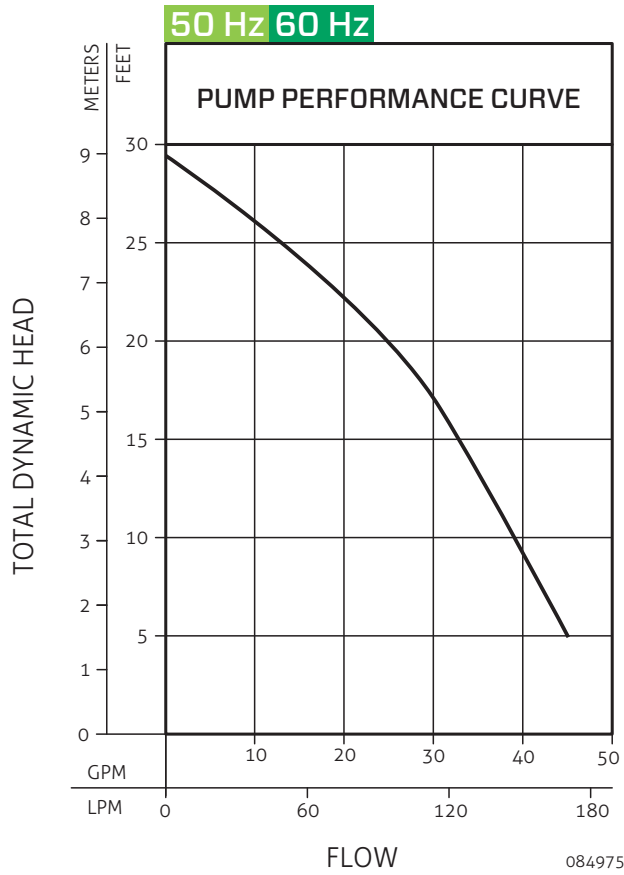

50 Hz

Model	Mode	Volts (V)	Ph Ø	Amps (A)	Motor		Weight	
					kW (p1)	HP	kg	lbs
201	Vertical Switch	220	1	3.3	0.71	1/2	13.5	29.8

60 Hz

Model	Mode	Volts (V)	Ph Ø	Amps (A)	Motor		Weight	
					HP	kW (p1)	kg	lbs
201	Vertical Switch	115	1	9.6	1/2	1.01	13.5	29.8

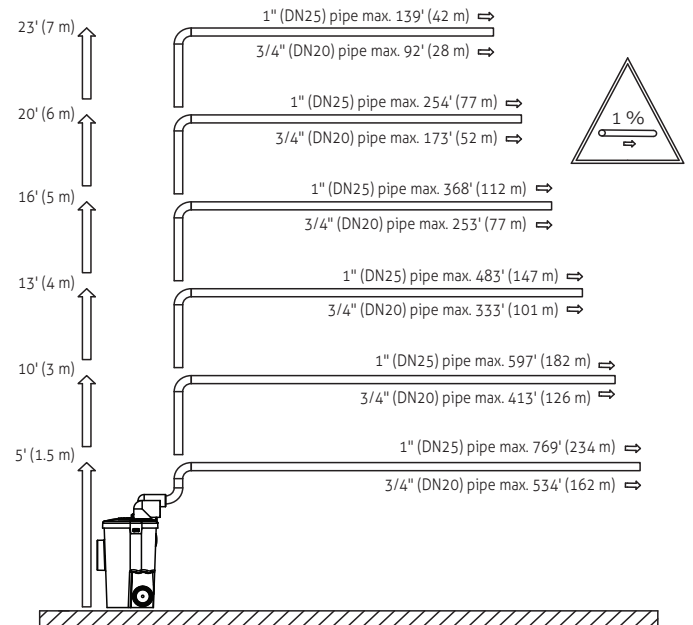
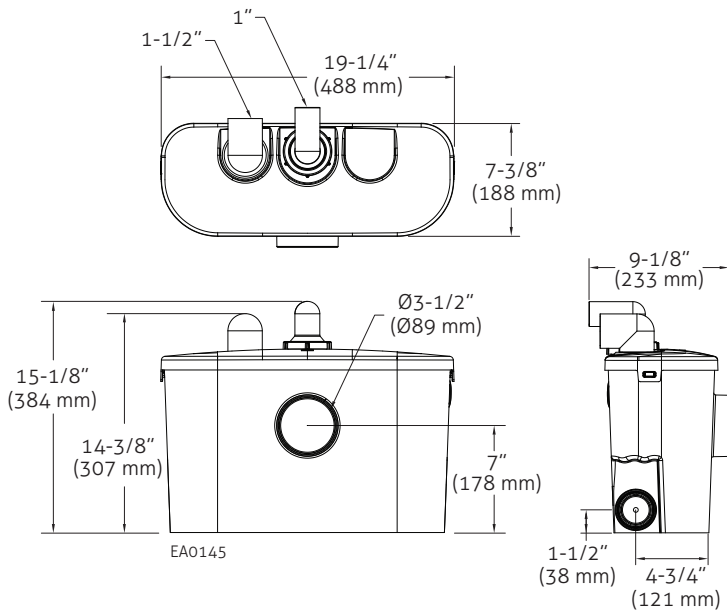

Product information presented here reflects conditions at time of publication. Consult factory regarding discrepancies or inconsistencies.

© Copyright 2022 Zoeller® Co. All rights reserved.
www.zoellerpumps.com

